

SEAMLESS BEND 30° SDR 11

Łuk formowany 30° SDR 11
Отвод Гнутый 30° SDR 11

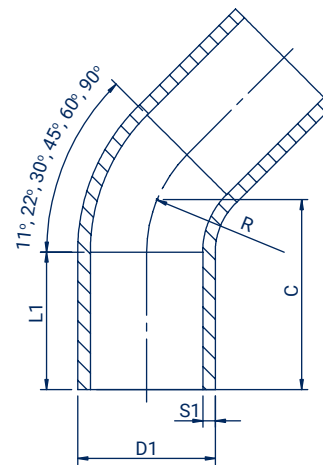

- **application: water and gas** | zastosowanie: woda i gaz |
применение: вода и газ
- **16 bar water, 10 bar gas** | 16 bar woda, 10 bar gaz |
16 бар - вода, 10 бар - газ
- **MRS - 10 MPa** | Минимальное сопротивление - 10 МПа
- **installation: electrofusion and spigot welding** | montaż: zgrzewanie elektrooporowe i doczołowe | установка: электросварная и стыковая



Size Wymiar Размер D1 (mm)	Code Kod Код	Angle Kąt Угол	L1 (mm)	C (mm)	S1 (mm)	R (mm)	Weight Waga Вес (kg)	Raw material Tworzywo Материал	Packing Pakowanie Упаковка
32	LU3003211	30	70	98	2,9	48	0,08	PE 100/PE100-RC	-
40	LU3004011	30	75	106	3,7	60	0,12	PE 100/PE100-RC	-
50	LU3005011	30	80	130	4,6	75	0,22	PE 100/PE100-RC	-
63	LU3006311	30	90	150	5,8	94,5	0,35	PE 100/PE100-RC	-
75	LU3007511	30	100	155	6,8	112,5	0,47	PE 100/PE100-RC	-
90	LU3009011	30	150	350	8,2	135	1,42	PE 100/PE100-RC	-
110	LU3011011	30	150	330	10	165	2,07	PE 100/PE100-RC	-
125	LU3012511	30	150	380	11,4	188	3,06	PE 100/PE100-RC	-
140	LU3014011	30	150	400	12,7	210	3,96	PE 100/PE100-RC	-
160	LU3016011	30	150	420	14,6	480	5,54	PE 100/PE100-RC	-
180	LU3018011	30	150	450	16,4	270	7,49	PE 100/PE100-RC	-
200	LU3020011	30	150	480	18,2	300	9,88	PE 100/PE100-RC	-
225	LU3022511	30	150	520	20,5	338	13,36	PE 100/PE100-RC	-
250	LU3025011	30	250	560	22,7	375	17,66	PE 100/PE100-RC	-
280	LU3028011	30	250	400	25,4	420	18,28	PE 100/PE100-RC	-
315	LU3031511	30	250	460	28,6	472,5	26,00	PE 100/PE100-RC	-
355	LU3035511	30	300	540	32,2	532,5	31,70	PE 100/PE100-RC	-
400	LU3040011	30	300	560	36,3	600	50,20	PE 100/PE100-RC	-
450	LU3045011	30	300	580	40,9	675	62,00	PE 100/PE100-RC	-
500	LU3050011	30	350	650	45,4	750	91,00	PE 100/PE100-RC	-
560	LU3056011	30	350	680	50,8	840	116,00	PE 100/PE100-RC	-
630	LU3063011	30	350	730	57,2	945	173,00	PE 100/PE100-RC	-

