

ZKR-111

ZAWÓR ZWROTNY KULOWY RÓŻNICOWY

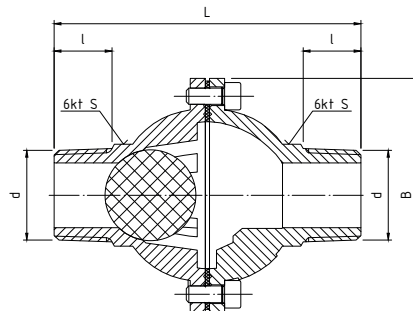

PARAMETRY (ZGODNE Z WYKRESEM P-T)

T _{MAX}	T _{MIN}	P _{MAX}	GZ wg
+120°C	+1°C	0,6 MPa	ISO 228

DANE TECHNICZNE



Wymiary w mm.

indeks	wielkość	DN	d	L	l	B	S
04-101-0250-000	1"	25	G1	112	18	85	37,0
04-101-0320-000	1¼"	32	G1¼	118	22	92	47,5
04-101-0400-000	1½"	40	G1½	140	25	108	51,0
04-101-0500-000	2"	50	G2	150	28	120	63,0

MATERIAŁY

KORPUS: żeliwo z powłoką malarską
USZCZELKA KORPUSU: NBR
 stal węglowa z powłoką galwaniczną

**KULA,
 ŚRUBY:**

WYKRES P-T

