

Deutsch

English

Français

Polski

Mess-, Regel- und
Überwachungsgeräte
für Haustechnik,
Industrie und Umweltschutz

Lindenstraße 20
74363 Güglingen
Telefon +49 7135-102-0
Service +49 7135-102-211
Telefax +49 7135-102-147
info@afriso.de
www.afriso.de

Betriebsanleitung



Instruction Manual / Notice technique/Instrukcja obsługi

Kesselsicherungsgruppe

Boiler safety group assembly
Groupe de sécurité chaudière
Grupa bezpieczeństwa

KSG

KSG 3 bar bis/up to/à/do 50 kW
KSG Maxi 3 bar bis/up to/à/do 100 kW

-  Vor Gebrauch lesen! / Read manual before use! / Lire la notice technique avant l'utilisation!/Przed użyciem przeczytaj instrukcję!
-  Alle Sicherheitshinweise beachten! / Observe all safety information! / Respecter toutes les consignes de sécurité !/Zapoznaj się z informacjami o bezpieczeństwie !
-  Für künftige Verwendung aufbewahren! / Keep manual for future use! / Conserver la notice technique pour toute utilisation ultérieure !/Zatrzymaj instrukcję na przyszłość !



1 Safety

1.1 Intended use

The boiler safety group assembly KSG may only be used for the following applications:

- In sealed heating systems as per EN 12828
- For heat generators with a heating capacity of up to 50 kW or up to 100 kW, depending on the version

The boiler safety group assembly KSG may only be used for the following media:

- Water
- Water/glycol mixtures

Any use other than the application explicitly permitted in this instruction manual is not permitted.

1.2 Predictable incorrect application

The boiler safety group assembly KSG must never be used in the following cases:

- Operation when the discharge opening is shut off
- Use with adherent, corrosive or flammable fluids
- Operation with media that have an adverse effect on the proper operation of the boiler safety group KSG
- Temperatures in excess of or below the permissible temperatures and pressures, see table 1, page 9

1.3 Safe handling

The boiler safety group assembly KSG represents state-of-the-art technology and is made according to the pertinent safety regulations. Each device is subjected to a function and safety test prior to shipping.

- ▶ Operate the boiler safety group assembly KSG only when it is in perfect condition. Always observe the operating instructions, all pertinent local and national directives and guidelines as well as the applicable safety regulations and directives concerning the prevention of accidents.

1.4 Staff qualification

The product may only be mounted, commissioned, operated, maintained, decommissioned and disposed of by qualified, specially trained staff.

1.5 Modifications to the product

Changes or modifications made to the product by unauthorised persons may lead to malfunctions and are prohibited for safety reasons.

1.6 Liability information

The manufacturer shall not be liable in any form whatsoever for direct or consequential damage resulting from failure to observe the technical instructions, guidelines and recommendations.

The manufacturer or the sales company shall not be liable for costs or damages incurred by the user or by third parties in the usage or application of this device, in particular in case of improper use of the device, misuse or malfunction of the connection, malfunction of the device or of connected devices. The manufacturer or the sales company shall not be liable for damage whatsoever resulting from any use other than the use explicitly permitted in this instruction manual.

The manufacturer shall not be liable for misprints.

2 Product description

The boiler safety group assembly KSG consists of a diaphragm safety valve, a pressure gauge and a quick air vent. The components are mounted on a carrier. The carrier is contained in an insulation piece.

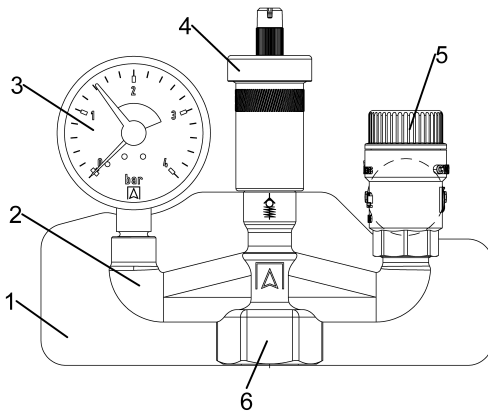





- 1 Insulation piece
- 2 Carrier with factory-installed components
- 3 Pressure gauge
- 4 Quick air vent with aqua stop
- 5 Diaphragm safety valve
- 6 Connection to heat generator

Fig. 1: Components of the boiler safety group assembly

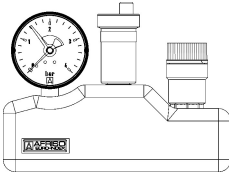
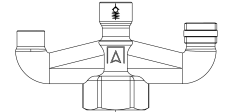

3 Technical specifications

Table 1: Technical specifications

Fig.	Parameters	KSG 3 bar	KSG Maxi 3 bar
	Dimensions with insulation (W x H x D)	183 x 144 x 70 mm	
	System pressure	3 bar	
	Temperature of medium	Max. 120 °C	
	Material	Brass	
	Bottom connection	G1	
	Inlet / Diameter	G ¹ / ₄ -PTFE / 63 mm	
	Range	0 - 4 bar	
	Green area	1,5 - 3 bar	
	Inlet	G ³ / ₈	
	Nominal pressure	12 bar	
	Response pressure	3 bar	
	Inlet x outlet	G ¹ / ₂ x G ³ / ₄	G ³ / ₄ x G1
	Heat capacity	50 kW	100 kW

4 Mounting/commissioning

WARNING Scalding due to hot liquids in the system.



- ▶ Take all necessary measures during mounting, commissioning and maintenance of KSG to ensure that hot liquids do not pose any hazard to persons.
- ▶ During heating up, liquid must be able to escape via the discharge line of the safety valve.
Install KSG in such a way that it **cannot be shut off**.
Do not install shut-off valves, filters or similar equipment.
- ▶ Install KSG in such a way that no external forces can act on the components when it is installed.



- ▶ Do not overheat KSG by welding or soldering work performed on the system. Install KSG after completion of such welding or soldering work.
- ▶ Verify that the nominal pressure of KSG corresponds to the planned value of the system.
- ▶ Verify that the liquid in the system and the application area of KSG are compatible.
- ▶ Thoroughly flush the pipes prior to installing KSG. Impurities such as weld beads, hemp or metal chips cause leaks of the safety valve.

4.1 Mounting the device

The safety valve and the pressure gauge are mounted with an elastic sealing system. If necessary, they can be rotated by up to 180° without the connection becoming leaky.

Observe the operating instructions of the diaphragm safety valve when mounting KSG.

1. Mount KSG in such a way that the components are vertical.
2. Mount KSG in such a way that the liquid can escape via the discharge opening of the safety valve without obstructions.
3. Mount KSG at the highest point of the heat generator or in its immediate vicinity at the flow line. A connection line with a maximum length of 1 m and the size of the inlet cross section may be installed between KSG and the heat generator.
4. Mount KSG with the insulation shells supplied with the unit (= heat insulation).

5 Maintenance

Refer to the operating instructions of the diaphragm safety valve.

When	Activity
Every 6 months	<ul style="list-style-type: none"> ▶ Verify that no accumulations can form in the system which can interfere with the discharge of the liquid from the safety valve or with the proper operation of the components ▶ Perform a visual inspection of the quick air vent ▶ Verify tightness of the quick air vent ▶ If the quick air vent is not tight, it must be replaced

6 Troubleshooting

Due to the integrated mounting valve, the quick air vent can be replaced while the system is under pressure.



Repairs may only be performed by specially trained, qualified staff.

1. If you need to perform work on the pressurised system, take all necessary precautions to ensure that such work on the pressurised system can be performed safely.
2. After repairs of the system, check the safety valve for proper operation, refer to the operating instructions of the diaphragm safety valve.

Table 2: Troubleshooting

Problem	Possible reason	Repair
Pointer of pressure gauge below green range	System pressure too low	▶ Fill liquid into the system until the pointer of the pressure gauge is in the green range
Pointer of the pressure gauge again below green range after filling of the system	Leak in system	▶ Check system for leaks

7 Customer satisfaction

Customer satisfaction is our prime objective. Please get in touch with us if you have any questions, suggestions or problems concerning your product.

8 Addresses

The addresses of our worldwide representations and offices can be found on the Internet at www.afriso.de.